



Anybus Wireless Bolt product

Anybus Wireless Bolt LTE

Anybus Wireless Bolt LTE

The Anybus Wireless Bolt LTE is an industrial grade router which provides high-speed transparent internet access to remote industrial machines via an LTE (4G) network with 3G fallback. This enables users to perform comprehensive remote monitoring and analysis targeting increased system uptime and reduced costly maintenance trips.



The robust IP66 and IP67-rated enclosure allows the Anybus Wireless Bolt LTE to be installed in the toughest of operating environments, and the wide temperature coverage (-40°C to 65°C) makes it suitable for outdoor applications.

The product can be powered through an Ethernet cable, i.e., Power over Ethernet, or via separate power terminals. Ethernet cables can be up to 100 meters long, enabling users to optimize the placement of Wireless Bolt LTE up to 100 meters from the connected industrial equipment.

As the rugged all-in-one solution can be installed in an exposed location, there is no need for an external antenna or antenna cable to the Wireless Bolt LTE. This has both financial and practical benefits, as external antennas can be expensive, fragile, and very sensitive to interference.

The Anybus Wireless Bolt LTE is packaged in an elegant and innovative form factor that blends in well, making it look like an integrated part of the installation.

High-speed cellular internet access

- Secure LTE Cat-4 connectivity for 4G networks with 3G fallback.
- Fast data transfer: Download up to 100 Mbit/s, Upload up to 50 Mbit/s.
- Nano SIM-card slot. The user can use any locally available SIM-card supporting LTE 4G (LTE Cat-4).
- Transparent transfer of any TCP/UDP based protocol, for example, MQTT and OPC UA.

All-in-one solution

- PoE (Power over Ethernet) option, use a single cable for both power and communication.
- Integrated dual antennas with MIMO support.
- GNSS satellite positioning function (GPS, GLONASS, Galileo and BeiDou).
- Built-in firewall, NAT, and DHCP server.
- Host interface RJ45 with Ethernet.

Designed for industrial use & harsh environments

- Industrial internet router ideal for applications within automation, transportation, telematics, public safety, and industrial IoT.
- Unique and industrial form-factor; M50 through-hole enables it to be mounted on any flat surface.
- Easy to use and configure - use the built-in web page or CLI with REST-commands for configurations and diagnostics.

Provides internet access for any machine, device, or equipment that has an Ethernet port.

- Provides satellite positioning for mobile or stationary equipment.

Application example:

- A rural area pump station with PLC controller using the Anybus Wireless Bolt LTE for internet connectivity.

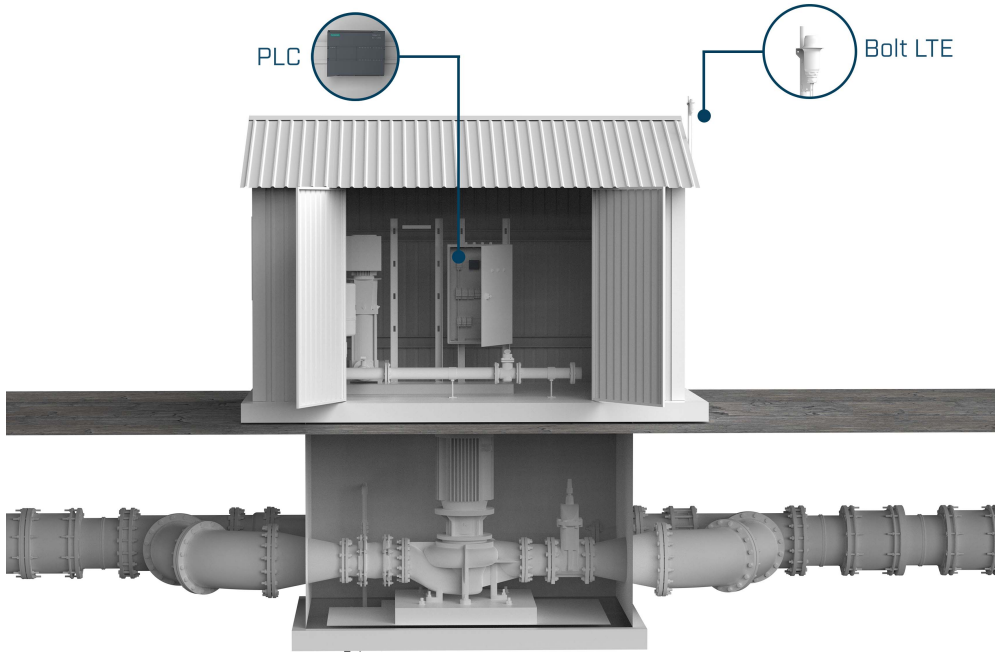

Figure 1: Pump station with PLC and Anybus Wireless Bolt LTE for remote monitoring and diagnostics.

Connectivity examples:

- Using PoE

The Anybus Wireless Bolt LTE supports PoE and as a result a single Ethernet cable can be used for both power and data.

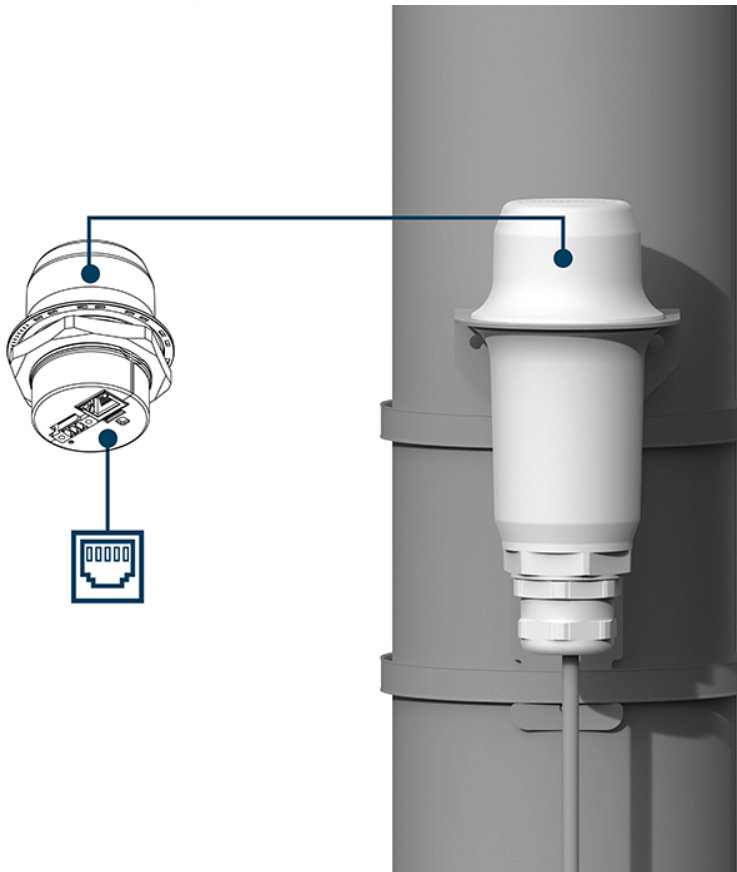

Figure 2: The Wireless Bolt LTE using PoE and mounted using the [Bolt Base Protector mounting kit](#)

- Using a separate power source

Alternatively, the Wireless Bolt LTE can be connected to a separate power source and only use the Ethernet cable for data.

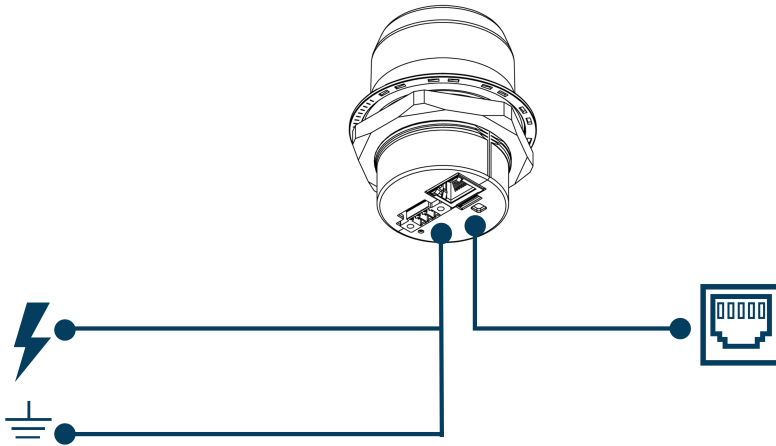

Figure 3: Connecting Bolt LTE with a separate power source and Ethernet cable

Technical Specifications

Operating temperature	Shadow Black and White version: -40 to 65°C Direct sunlight Black: -40 to 45 °C, White: -40 to 65°C
Storage temperature	-40 to 85 °C
Host interface.	RJ45 Ethernet 10/100 Mbit/s, PoE (Power over Ethernet)
Humidity compatibility	EN 60068-2-78: Damp heat, 40 °C, 90% (non-condensing).
Vibration compatibility	Sinusoidal vibration test according to IEC 60068-2-6:2007 and with extra severities Number of axes: 3 mutually perpendicular (X:Y:Z) Duration: 10 sweep cycles in each axes Velocity: 1 oct/min Mode: in operation Frequency: 5-500 Hz Displacement ±3.5 mm Acceleration: 2g Shock test according to IEC 60068-2-27:2008 and with extra severities Waveshape: half sine Number of shocks: ±3 in each axes Mode: In operation, Axes ± X,Y,Z Acceleration: 30 m/s ² Duration: 11 ms.
Dimensions	Diameter: 68 mm. Height: 75 mm without Power connector, 84 mm incl. Power connector. Height above mounting surface: 41 mm.
Weight	100g
Mounting material	Top: Valox 357X(f1) PBT/PC. Suitable for outdoor use with respect to exposure to ultraviolet light, water exposure and immersion in accordance with UL 746C. Base: Celanex: XFR 6840

	GF15. PBT glass reinforced plastic.
Protection class	Top (outside of host): IP66 and IP67 / UL Type 4X Base (inside of host): IP21
Mounting	M50 hole (50.5 mm hole diameter needed)
Power	3-pin screw connector and PoE (Power over Ethernet) 11-33 VDC through Power connector, PoE, IEEE 802.3at Type 1 (Class 0) Power Consumption: Sleep Mode: Power connector 0.1 W. PoE 0.3 W Idle Mode: Power connector 0.6 W. PoE 0.8 W Worst Case average power: Power connector 3.2 W. PoE 3.6 W. Worst case peak current: 1.2A@11VDC
Cellular standards, Bands	EMEA: LTE B1, B3, B7, B8, B20, B28. Fallback 3G. Americas: LTE B2, B4, B5, B12, B13, B14, B25, B26, B66. Fallback 3G.
Data speeds	Max download speed: 100 Mbit/s Max upload speed: 50 Mbit/s
Ethernet protocols	Transparent transfer of any TCP/UDP based protocol, Built-in firewall, NAT, and DHCP server.
Certifications	CE/RED, FCC, PTCRB, UL/cUL (E214107) Pending: Verizon, AT&T
Positioning	GNSS satellite positioning function (GPS, GLONASS, Galileo and BeiDou)

File	Version	Size	Read online
------	---------	------	-------------

Order Codes	Black EMEA: AWB1500 Americas: AWB1502	White top and black base EMEA: AWB1501 Americas: AWB1503
Included Components	Anybus Wireless Bolt LTE with 3-pin power screw connector. Quick start Guide, Safety & Compliance sheet. Global roaming SIM-card (optional activation with separate charge)	
Accessories	<p>024707 - Power Supply 90-264 VAC to 24VDC 19W world socket kit, 1.4-meter cable and 3-pole Bolt power connector.</p> <p>024708 - Bolt base Protector; Read more about the base protector here.</p> <p>024709 - Bolt base Protector and Mounting Bracket kit; Read more about the base protector here.</p> <p>024715 - Replacement Power plugs for Anybus Wireless Bolt, bag with 5pcs, 3-pin with screw terminals and screw fastening, symbols +-PE</p> <p>AWB4005 - Anybus PoE injector 100-240VAC. 35W incl. world power cable</p> <p>AWB4006 - Anybus PoE injector 12-57VDC. 30W, dual PoE ports</p>	
Warranty	3 years	