

# M133TG

## Intel® Core™ i5 1135G7 Industrial Ultra Rugged Tablet



### KEY FEATURES

- 13.3" 1920 x 1080 IPS wide viewing angle LED panel
- Intel® Core™ i51135G7 Tiger Lake processor
- Removeable kickstand usable as carrying handle
- Magnesium alloy housing with allaround elastomeric rubber
- IP65 waterproof and dustproof
- Fanless cooling system



### SPECIFICATIONS

Display			
<b>Resolution</b>	1920x1080	<b>Size</b>	13.3 inches
<b>Contrast Ratio</b>	1000:1	<b>Panel Brightness</b>	500.0 nits
<b>View Angles</b>	89,89,89,89	<b>Type</b>	Projected Capacitive Multi Touch
<b>Bonding</b>	Optical Bonding for Sunlight Viewability		
System Specification			
<b>Processor</b>	Intel Core i5-1135G7 2.4GHz (up to 4.2GHz)	<b>Memory</b>	4GB DDR4 SDRAM 8GB DDR4 SDRAM (Optional) 16GB DDR4 SDRAM (Optional) 32GB DDR4 SDRAM (Optional)
<b>Storage</b>	128GB SSD Additional storage available with micro SDXC card slot 256GB SSD (Optional) 512GB SSD (Optional) 1TB SSD (Optional) 2TB SSD (Optional)	<b>Ethernet controller</b>	1 x RJ45-10/100/1000 Mbps LAN
<b>Security</b>	Trusted Platform Module (TPM) 2.0 Kensington Lock	<b>Operating System</b>	Windows 10 IoT Enterprise LTSC (64 bit) Windows 11 IoT Enterprise SAC (64 bit) (Optional)
<b>WLAN</b>	Support	<b>BT</b>	Support
<b>WWAN</b>	4G LTE (Optional)	<b>GNSS</b>	GPS/GLONASS
<b>RFID</b>	HF RFID reader 13.56 MHz (Optional)		
Mechanical			
<b>Dimension</b>	338.2 x 239.8 x 33.8 mm	<b>Weight</b>	2.4 Kg (Without Kickstand), 2.5 Kg (With Kickstand)
<b>Cooling System</b>	Fanless thermal design		
IO Ports			
<b>USB Port</b>	5 x USB 3.0 Type A, 1 x USB 3.0 Type C	<b>Serial Port</b>	1 x RS232 (DB9)
<b>SD Card Slot</b>	1 x SDXC Slot	<b>Audio</b>	2 x 1 watt speaker
<b>LAN</b>	1 x RJ45-10/100/1000 Mbps LAN	<b>Indicator</b>	4x LED Indicator for Power, Battery, SSD, RF status
<b>Docking Connector</b>	1 x Docking connector		
Environment			

<b>Operating Humidity</b>	30% to 80% RH, non-condensing	<b>Operating Temperature</b>	-10°C to 50°C (14°F to 122°F)
<b>Storage Temperature</b>	-20°C to 60°C (-4°F to 140°F)	<b>Shock</b>	MIL-STD-810G Method 516.6 Procedure I
<b>Vibration</b>	MIL-STD-810G Method 514.6 Procedure I	<b>IP rating</b>	IP65
<b>Drop</b>	MIL-STD-810G Method 516.6, 4 ft		

**Certification**

**Certification** CE, FCC

**Security Function**

**Kensington Lock** Kensington Lock Support

**Control**

**Button** 1 x Power, 1 x menu, 2 x volume key  
3 x Programmable Function Keys

**Camera**

**Rear Camera** 8MP Rear Camera with auto-focus and LED light

**Power**

**Battery** 15.4V, typ. 5900 mAh Li-Polymer Battery (4S1P) Hot-Swap (Optional)      **Battery Operating Time** More than 10 hours (BAPCo TabletMark v3)

**Power Rating** 19V DC      **Adapter** 100-240V, 50-60Hz / 19V DC

**Accessory**

**Accessory** Adapter and Power Cord  
Standard Battery  
Stand with Integrated Handle      **Optional Accessory** Vehicle Charger (Optional)  
Battery Charger (Optional)  
Desk Docking (Optional)

**Barcode Scanner**

**Barcode Scanner** 1D/2D barcode reader (Optional)

**DIMENSIONS** UNIT:MM

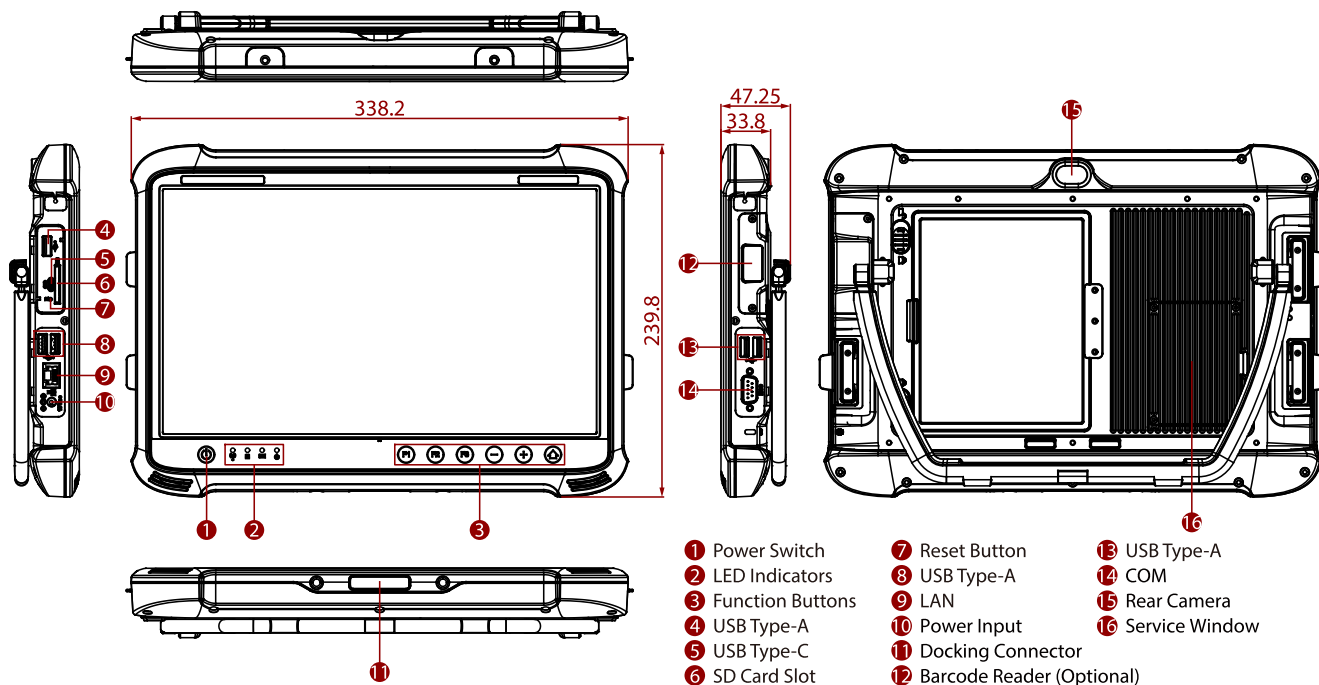

## NOTE

1. This is a simplified drawing and some components are not marked in detail.
2. Please contact our sales representative if you need further product information.
3. All specifications are subject to change without prior notice.
4. The product shown in this datasheet is a standard model. For diagrams that contain customized or optional I/O, please contact the Winmate Sales Team for more information.